

13162**BMW X5****9/16/2013**

GROSS LOAD CAPACITY WHEN USED AS A WEIGHT CARRYING HITCH: 6,000 LBS. TRAILER WEIGHT & 600 LBS. TONGUE WEIGHT.
 GROSS LOAD CAPACITY WHEN USED AS A WEIGHT DISTRIBUTION HITCH: 6,000 LBS. TRAILER WEIGHT & 600 LBS. TONGUE WEIGHT

DO NOT EXCEED VEHICLE MANUFACTURER'S RECOMMENDED TOWING CAPACITY.

HAVING INSTALLATION QUESTIONS? CALL TECHNICAL SUPPORT AT 1-800-798-0813

Parts List			
ITEM	QTY	PART NUMBER	DESCRIPTION
1	1	1_2 - 13	RIVET NUT
2	1	FW12	FW, 12, ZP
3	1	1/2"	LOCK WASHER
4	1	1/2"	CONICAL TOOTHED WASHER
5	1	1/2-13 x 1 3/4	HEX BOLT
6	6	3/8"	CONICAL TOOTHED WASHER
7	6	M10 - 1.5 X 50 HEX	HEX BOLT
8	6	13162-TS	3/4" x 11 GA TUBE SPACER

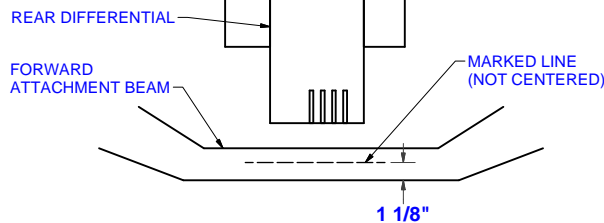
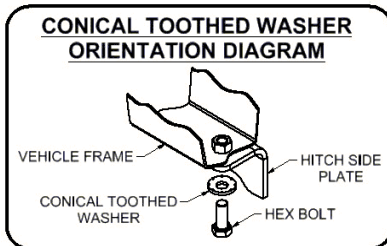
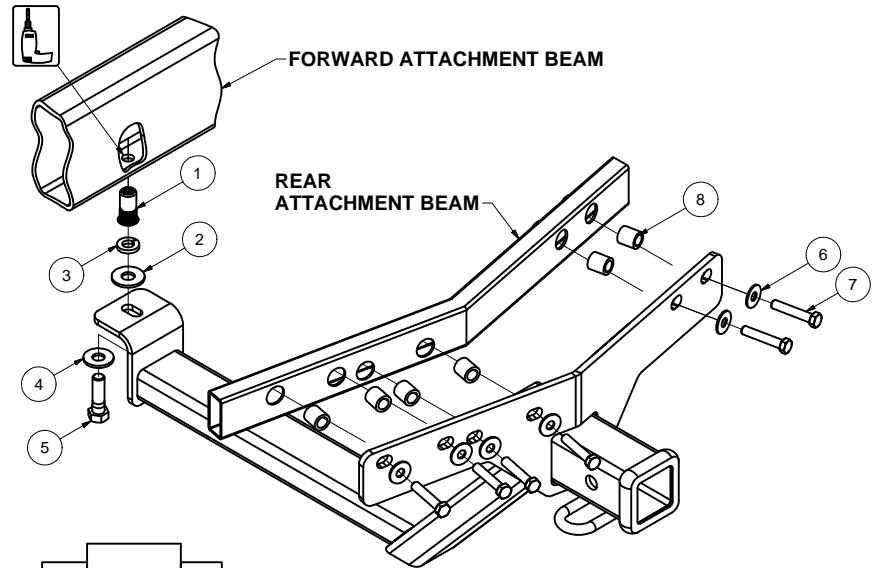

FRONT
REAR

HITCH WEIGHT: 22 LBS.

INSTALL TIME

PROFESSIONAL: 60 MINUTES

NOVICE (DIY): 120 MINUTES

INSTALL NOTES:

- DRILLING REQUIRED
- TRIMMING REQUIRED
- MUST REMOVE BUMPER FASCIA

INSTALLATION STEPS

1. Remove the bumper fascia by removing (4) screws from inside the rear fenders. Remove each trim ring and fascia center door and remove (1) screw above each exhaust opening. Pull the bumper fascia straight back to remove.
2. Remove the (6) existing M10 fasteners from the rear attachment beam and return to owner.
3. Measure and mark 1 1/8" from the front on the bottom of the forward attachment beam as shown above.
4. Raise hitch into position and install the (2) outermost bolts and spacers, snug.
5. Mark the slot toward the front of the vehicle, remove the hitch, and drill a 1/2" hole where the measurement in step 3 meets this mark.
6. Enlarge the drilled hole to 11/16" and loosely reinstall hitch with all (6) 10mm bolts and spacers - to allow movement as needed.
7. Insert the rivet nut, lock washer, washer, hitch, conical washer and bolt as shown above. **Press hitch up to vehicle tightly** and torque bolt to 45 lb-ft. Remove bolt and conical washer to remove lock washer and washer, then reinstall bolt and conical washer.
8. Torque all M10 fasteners to 45 lb-ft and all 1/2" fasteners to 110 lb-ft.
9. Trim the bumper fascia to allow clearance for hitch main body tubes, approximately 2 3/4" wide X 4 1/2" long centered on the lower bumper fascia. Re-install the bumper fascia and either return the center door to the vehicle owner or trim to allow the receiver to pass through when re-installed.

PERIODICALLY CHECK THIS RECEIVER HITCH TO ENSURE THAT ALL FASTENERS ARE TIGHT AND THAT ALL STRUCTURAL COMPONENTS ARE SOUND.

Curt Manufacturing LLC., warrants this product to be free of defects in material and/or workmanship at the time of retail purchase by the original purchaser. If the product is found to be defective, Curt Manufacturing LLC., may repair or replace the product, at their option, when the product is returned, prepaid, with proof of purchase. Alteration to, misuse of, or improper installation of this product voids the warranty. Curt Manufacturing LLC.'s liability is limited to repair or replacement of products found to be defective, and specifically excludes liability for incidental or consequential loss or damage.